

9VX

Mini Excavator



**0.7 – 0.95m
variable width**

Smooth operation

Easy maintenance



IHI

COMPACT EXCAVATORS



Wide Spanner

Spanner function (700 – 950 mm has been equipped as standard. The wide span amount contributes to stability while allowing entry into tight spaces.



Bucket cylinder hoses are located inside arm

Improves forward visibility and helps prevent damage to the hose.



Rugged pressed steel full opening engine cover

Pressed steel engine cover for easy repair. No degradation in quality if exposed to sunlight over long periods.



Aluminium radiator resists corrosion

Plastic fuel tank and aluminium radiator for long life and resistance to rusting.

9VX Specifications

Model	9VX
Performance	
Bucket capacity	0.022 m ³
Bucket width	370 mm
Operating weight	965 kg
Transportation weight	890 kg
Swing speed	0.87 rev/min
Travel speed (low/high)	1.7/3.5 km/h
Gradeability	58% (30°)
Ground pressure	26.2 kPa (0.27 kgf/cm ²)
Max. bucket digging force	10.6 kN (1086 kgf)
Engine	
Model	YANMAR 2TNV70
Rated output	7.3 kW (9.9 hp)/ 2400 rpm
Fuel tank capacity	8.5 L
Boom swing system	
Type	Boom offset with hydraulic cylinder
Swing angle (L / R)	50° / 90°
Hydraulic system	
Pressure	16.2 MPa (165 kgf/cm ²)
Pump hydraulic flow	11.1 L/min x 2
Dozer blade	
Size	700 mm x 240 mm
Lift above ground / Drop below ground	220 mm / 150 mm
Options	
<ul style="list-style-type: none"> • Long-arm (standard + 200 mm) • Auxiliary hydraulic piping • Additional dozer blade • Roll bar • Gate lock lever 	
Bucket	
0.011 m ³ digging bucket (220 mm width)	
0.017 m ³ long arm bucket (320 mm width)	

Eco-Friendliness and Safety

- Conforms to EC low noise regulations.
- Equipped with automatic swing parking brake as standard.

Easy Operation

- Improved stability with wide span (700 mm– 950 mm).
- Top class tail swing radius of 485 mm.
- One-point lifting for easy loading on truck.
- Only 1435 mm diameter for full rotation (at 90° right swing).

Easy Maintenance

- Plastic fuel tank guards against rusting.
- Aluminium radiator resistant to rusting.
- Segmented boom cylinder hose for easier maintenance.

Rugged Body

- Rubber tracks not only offer superior durability but also high ground gripping power.
- Full opening engine cover fabricated from steel.
- Equipped with rugged dozer blade.
- Bucket cylinder hoses located inside boom, guarding against damage.

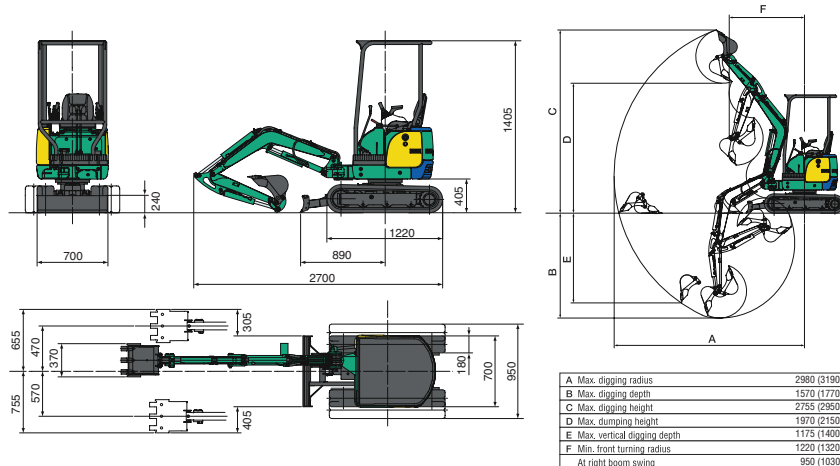

Note: Due to a policy of constant innovation, specifications may be subject to change.